

Environment Profile for Karur district

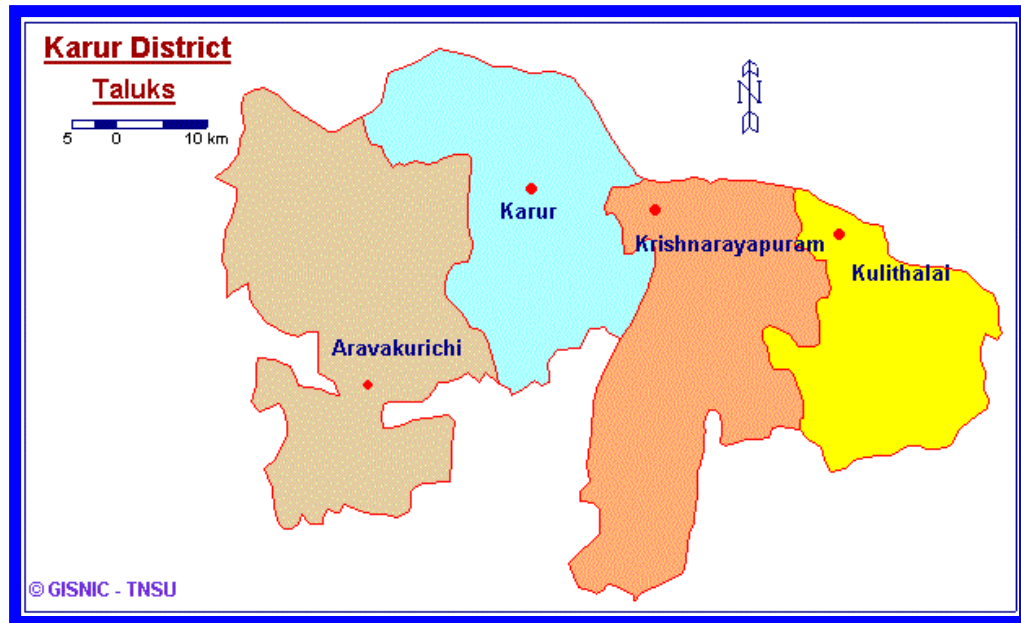

1

The context

The **Department of Environment (DoE)** is the nodal department for dealing with environmental management of the State. The State has been endowed with multitude of natural resources, judicious management of, which is essential for sustainable development in all sectors. Effective resources management calls for an in-depth assessment of their existing conditions and trends. A cursory evaluation of the present status of our environment and natural resources including land, soil, water, air and the life support systems like forests, rivers, coastal areas indicate that the health of such systems are threatened by

serious levels of degradation. Though different Government Departments / Agencies are responsible for management of resources under their jurisdiction, information relating to the individual sector lie fragmented.

To manage the environment in a holistic manner and to develop an environment friendly sustainable development perspective, it becomes necessary to identify the gaps in the present management of resource bases. Such intervention would be realistic only if there is a strong database with data collected from the primary/secondary sources, compiled and presented in the form of district environment profiles. Thus the **AIMS Research** (A Joint Venture of TCW/ICICI, IDBI and ICICI) – one of the country's leading consultancy and research organisation has been engaged for the preparation of such a report. This report will form the basis for developing **district level environmental management plans** that will spell out specific action programs to be implemented by local/state institutions. This Report provides a brief account of the manner in which the **District Environment Profile for Karur district** has been prepared and presented.

To achieve certain degree of uniformity in the presentation of environmental data in the districts, it is considered necessary that certain forms may be prescribed for collection and presentation of the relevant data besides interpretations of the data thus collected. Accordingly the

data compiled in the prescribed formats have been synthesised and presented in the following chapters.

2

Background

Karur is the centrally located district in Tamilnadu State. It is bounded on the north by Namakkal district and Musiri taluk of Thiruchirappalli district, on the east by Thiruchirappalli and Pudukkottai districts, on the south by Sivagangai, Madurai and Dindigul districts and on the west by Dindigul and Erode districts. The administrative headquarter of this district is located at Karur.

In September 1995 Thiruchirappali district was divided into three districts namely Thiruchirappalli, Karur and Perambalur districts. According to the said trifurcating, Karur revenue division of 1981 census, which comprised of three taluks namely Karur, Manapparai and Kulithalai were detached from the erstwhile Thiruchirappali district to form this district.

Languages and religion

Main languages spoken in the district are Tamil, Kannada, Malayalam, Telugu and Urdu. Religion-wise break-up of population of the district as per 1991 Census is indicated below:

Hindus: 1061524, Christians: 45514, Muslims: 46399, Jains: 2, Sikhs: 54, Other religious and persuasions: 1 and Religion not stated: 60.

Fairs and festivals

The people of Karur, Kulithalai and Kulathur venerate Goddess Mariyamman, which draw record crowds. Christians and Muslims festivals are also celebrated in this district with fun and fare.

2.1 Geographical location of the district

The district lies between $10^{\circ} 63'$ and $11^{\circ} 14'$ north latitude and $77^{\circ} 90'$ and $78^{\circ} 61'$ east longitude. Cauvery river and Amaravathi river is flowing in the district and normally found to be dry during the summer season. Broken and isolated masses of crystalline rocks, are found in the Vellimalai (silver hills) in the south of Kulithalai taluk, Rangamalai rocks (945 metres) in the extreme south of Karur taluk, the golden rock and the great fort. The soil found in the Karur taluk is of a very poor quality. The soil is best suited for raising dry farming crops. Karur district consists of Four Taluks, namely 1.Karur, 2.Aravakurichi, 3.Kulithalai and 4.Krishnarayapuram. The total geographical area of the district is about 2256.18 sq.km. The district is divided into 8 Blocks. The details of the name of the taluks are given in the following table:

| Sl.No. | Name of Taluks | |
|---------------|-----------------------|-------|
| 1 | Karur | 50444 |

| | | |
|------------|------------------|--------|
| 2 | Aravakurichi | 66858 |
| 3 | Kulithalai | 38039 |
| 4 | Krishnarayapuram | 70277 |
| Total Area | | 225618 |

2.2 Administrative arrangement in the district

Karur district comprises 4 taluks, 8 blocks and 172 villages. As regards the hierarchy of administrative arrangement, there are 13 town panchayats, 156 village panchayats and 2 municipalities in the district. The details regarding the number of blocks, villages, village panchayat, town panchayat and village panchayat with regard to each taluk are given in table No: 1.

2.3 Meteorological information

The monthly average rainfall in the district is worked out to be 73.8 mm. The months of August, September, October, November and December receive a rainfall that is more than the annual average rainfall. The average number of rainy days, mean maximum temperature, mean minimum temperature and mean relative humidity for the period 1991-96 are given in table no.2.

2.4 Demographic details

The growth of population over the past four decades and the essential characteristics of the population for the past few decades in terms of birth rate, death rate, infant mortality rate in the district and literacy level are given in tables: 3,4 & 5.

2.4.1 Population

The population of Karur district has grown from 7,56,757 in 1981 to 8,54,162 in 1991 with an average growth rate of 1.28% per annum. According to the 1991 census of Karur taluk is the most thickly populated and Krishnarayapuram taluk is the least populated in the district. The details of population growth along with the Growth Rate-taluk wise are given in Table No: 3.

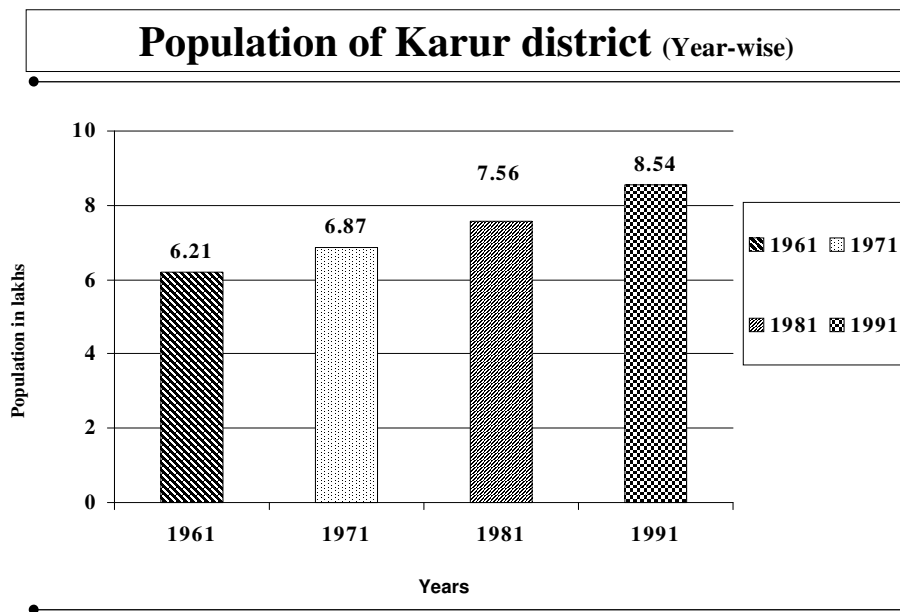

2.4.2 Trend in birth/death rate and infant mortality rate

There has been steady decline in birth rate, death rate

and infant mortality rate over the decades in the district. The birth rate was 29.5 in 1961, and 17.2 in 1991 (Figures-per thousand) and the death rate from 10.5 in 1961 and 5.7 in 1991 (Figures-per thousand). The infant mortality rate has also gone down from 37.2 in 1961 to 23.2 in 1991 (Figures-per thousand). The details of birth rate, death rate and infant mortality rate over the past four decades are given in table No.4. (Refer table no.4).

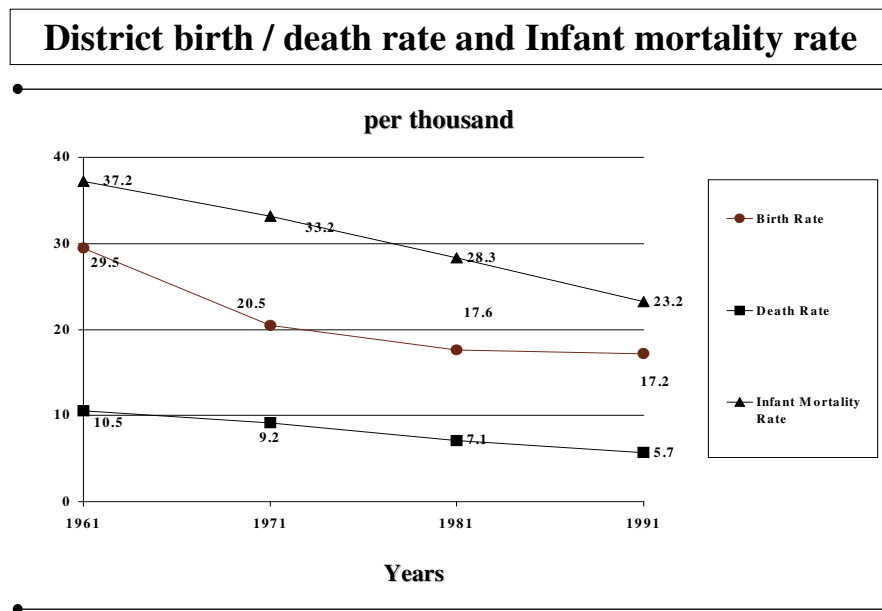

2.4.3 Literacy level among the population

The literacy level of Karur district according to figures available for the year 1996 is 53.13% with male literacy level being more than the female literacy level. It is also observed while the male literacy level has decline from 54.57% in 1981 to 53.13% in 1996, there has been a

significant increase of female literacy level also from 26.89% in 1981 to 33.65% in 1996. The information on literacy level of the district is given in table no: 5.

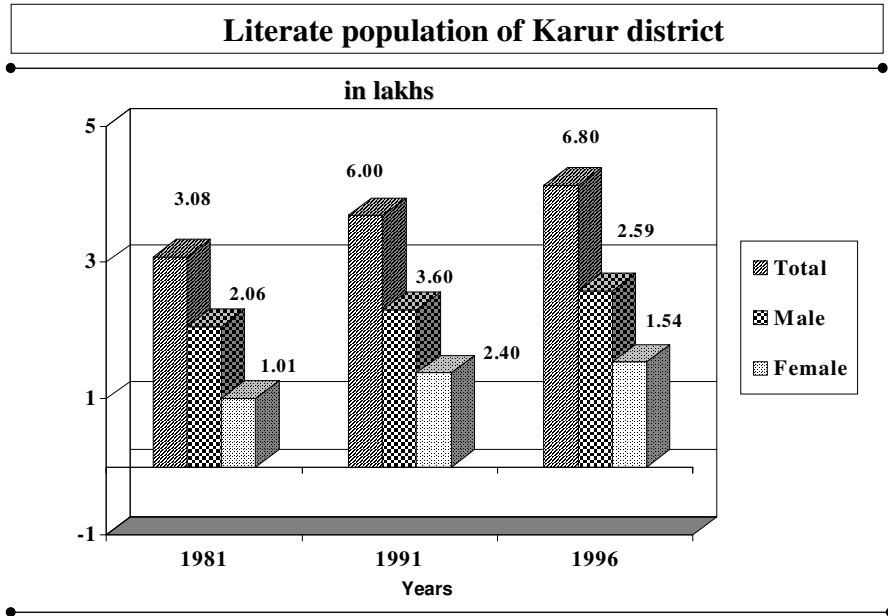

Education

The following table provides information on types/levels of educational facility available in the towns of this district. It also indicates the number of stadia and public libraries available therein:

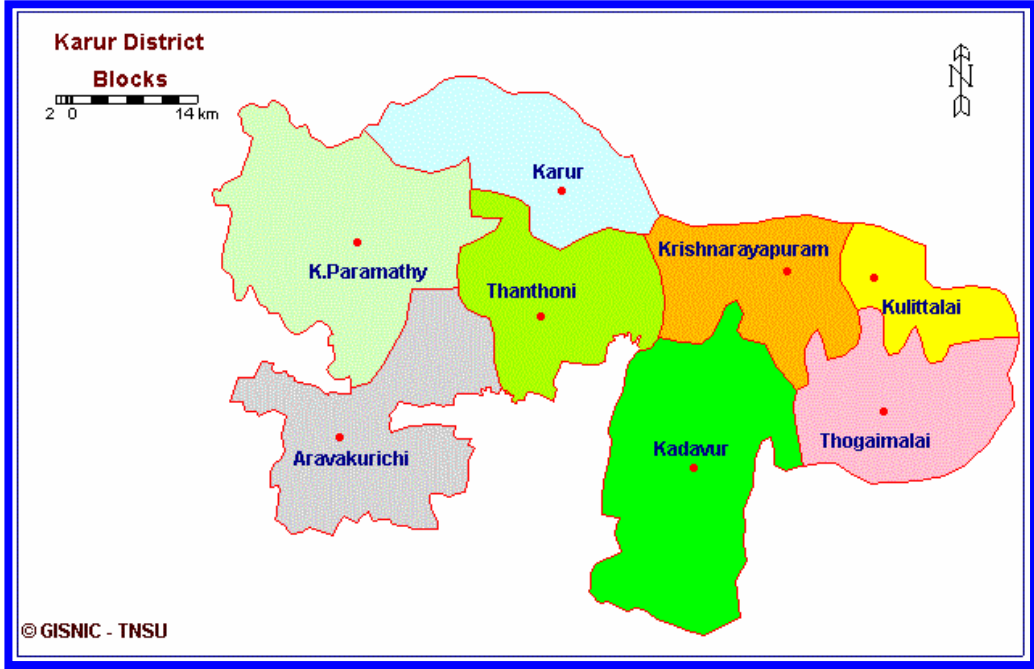

| S. No | Name of the towns | Educational institutions | State libraries including reading rooms |
|-------|-------------------|---|---|
| 1 | Karur U.A | Secondary/Matriculation School (1), Junior Secondary and Middle school (1), Primary schools (7) | PL:1 |
| | I) Inam Karur | | |
| | II) Karur | Arts and Science College (1), Higher secondary/Intermediate schools (4), Secondary/Matriculation schools (6), Junior Secondary and Middle school (13), Primary schools (23) | PL:3 RR: 5 |
| 2 | Kulithalai | Higher Secondary/Intermediate schools (2), Secondary/Matriculation schools (2), Junior Secondary and Middle schools (3), Primary schools (6) | PL:1 |
| 3 | Manapparai | Higher Secondary/Intermediate school (1), Secondary/Matriculation schools (6), Junior Secondary and Middle school (13), Primary schools (23) | PL: 1 |
| 4 | Pallappatti | Higher Secondary/Intermediate schools (1), Secondary/Matriculation schools (4), Junior Secondary and Middle schools (6), Primary schools (10) | PL: 1 |
| 5 | Punjai Pugalur | Higher Secondary/Intermediate schools (1), Secondary/Matriculation schools (2), Junior Secondary and Middle school (2), Primary schools (11) | PL: 1 RR: 2 |

Resources - availability, use and environmental status

3.1 Land resources

Resources of the district, their availability, use and environmental status is discussed in the following chapters.

3.1.1 Agriculture and horticulture

Agriculture and irrigation

The economy of the district is mainly agriculture. The chief sources of irrigation are the rivers. The principal cereal crops of this district are paddy, cholam (maize), Ragi and Cumbu (millets). Among pulses, the major crops are red-gram, black-gram, green-gram and horse-gram. Pulses are predominantly cultivated as rainfed crops. Oil seeds are grown throughout the district as a summer crop. Among oil seeds, groundnut, gingelly (sesame) and castor occupy important places. Bananas, citrus fruits, mangoes and grapes are popular fruits cultivated in the district.

i. Land utilisation

The total geographical area of the district was 2256.18 sq.km in 1995-96. Cropped area accounts for about 44.59% of the total area. Forestlands cover about 2.74% of the total land. A major portion (52.67%) of the land falls under the category of 'non available for cultivation', 'fallow lands' and 'other uncultivable land'. The land utilisation pattern in Karur district (Block-wise) is given in

table no: 6.

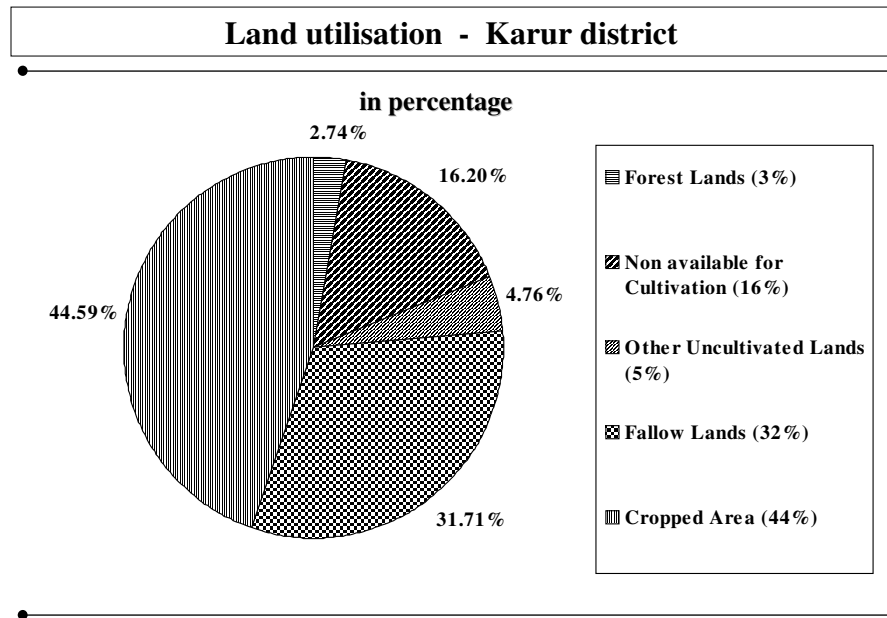

ii. *Trend in production and productivity of important crops*

Cereals, pulses and oil seeds are observed that the three important crops produced in the district. The productivity pattern over the past 3 years indicates that the productivity of cereals, pulses and oil seeds have fluctuations. The significant feature is the increase in the area under production of oil seeds, cereals and pulses in the years 1995-96. The details on the productivity performance of the district in relation to cereals, pulses and oil seeds for the past 4 years are given in table no: 7.

iii. Horticultural and plantation crops

There were fruit crops with an yield of 2,05,530 tonnes, vegetables crops of 6,780 tonnes and plantation crops of 10 tonnes cultivated in 5,892 ha 2,379 ha and 17 ha respectively in the years 1995-96 (Refer Table No: 8).

iv. Consumption of fertilisers and pesticides

About 20,422 metric tonnes of Chemical Fertilisers were used in 1997-98, out of which 50.93% constitutes the nitrogenous fertilisers. 13000 pockets of Bio-fertilisers were used in Karur district in 1997-98. The details on the total of consumption (Block wise details are not available) fertilisers and pesticides are given in table no: 9.

v. Trend in consumption of fertilisers and pesticides

Consumption of Bio - fertilisers has increased 8.33% only in 1996-97. Maximum of dust consumed (50%) in 1995-96 and least (5.03) in 1996-97. Details about the trend in consumption of fertilisers and pesticides are given in table no: 10.

vi. Soil types

Block soil is the predominant soil type in this district accounting for 35.51% followed by lateritic soil for 23.85%. The other type of soil is sandy, coastal alluvium for 20.31%. The details are given in table no: 11.

vii. Soil problems

Information is not available for identifying the soil problems that are prevalent in the district (Refer Table

No.12).

viii. *Status of soil and water conservation programs*

Soil conservation works were undertaken in district over an area of 22,519 ha. Other details of construction of check dams/stop dams in the district are not available for the district (Refer Table No: 13).

Animal husbandry

Cattle, sheep and goats are the main livestock of the district. As a consequence of animal husbandry department's scheme like the supply of pedigreed bulls, key village schemes, setting-up of artificial insemination centres etc., the livestock population in the district has improved.

The district being an inland district without coastal line, fishing is convenient in inland waters. Fast growing fish fingerlings of the gangetic carps like sale, mrigal, rohu and gatla are stocked regularly and distributed to these fishing centres. Each fishing centre has fishermen's co-operative, which gives fishermen loans for purchase of fishing implements and to discharge prior debts. These societies also get lease of fishing rights of inland waters and distribute the leases to their members.

3.1.2 Forest resources

i) *Forest area*

There are 17 forest areas in Karur district constituting

a total area of 9149.889 ha. (91.49 sq.km). 7 areas fall under the reserve forest category with 3246.49 (32.46 sq.km) hectares, 10 under reserve land category with 5903.40 (59.03 sq.km.) hectares. The details regarding the classification of forest area with their extent are given in Table No: 14.

ii) *Green cover classification of forest*

In composite Thiruchirapalli district, total area of forest was 99169 ha. Dense and sparse forest are 14111 ha and 11157 ha respectively. There are 69 ha of grass land in this region Degraded forest area cover is 5097 ha in this district. The given figures are composite figure of Karur and Thiruchirappali district. (Refer Table No. 14.b)

iii) *Trend in per capita forest area*

There is no variation of forest area from 1961 to 1991 in the district. The per capita forest area has shown decreased trend from 0.015 ha in 1961 to 0.011 ha in 1991. The details are given in Table No: 15.

iv) *Man made forest plantations*

Information about man made forest plantations are not available in the district (Refer Table No: 16).

v) *Details of villages abutting forest area*

Details of villages abutting forest area are not available in the district (Refer Table No: 17).

vi) *Tribal villages*

There are no tribal hamlets located in this district.

(Refer Table No: 18).

vii) *Forestry area diverted for non forestry purposes*

The district does not have any forestry area diverted for non-forestry purposes. (Refer Table No: 19.)

viii) *Trends in production of forest produce*

Statistical data are not available about trends in production of forest produces (Refer Table No: 20).

ix) *Conservation of biological resources, wild life census, rare/threatened species of flora and fauna*

There is no conservation of biological resources in the district. Wild life census is not available in the district one rare species *Pterasperrum reticulate* and vulnerable species *Pavetta hohenackeri* are identified in this district. Necessary information is furnished in table nos.: 21,22 & 23.

3.1.3 Mineral resources

Quartz, feldspar and lime stone are the mineral resources in the district. Statistical information about these minerals is furnished in Table No: 24.

3.2 Water resources

3.2.1 River canals and water ways

The amaravathi river originates from Thirumurthimalai in Udamalpettai taluk of Coimbatore district. The river flows through Erode district and thereafter into Karur district. The water of Kodavanar and Nankanchi rivers joins the Amaravathi river 20 Kms ahead

of Cauvery. The river thereafter merges with Cauvery river near mayanur villages. Amaravathi River is the main source of water from domestic and irrigation purposes. Shanmuganadhi and Kodaganar river are the tributaries of Amaravathi river.

River cauvery runs on the northern side of Karur and Kulithalai taluk. Of the three major tributaries of river cauvery the noyyal and amaravathi run through Karur taluk before joining cauvery. But due to discharge of effluents of the Thiruppur dyeing units, the water in the river has become unfit for irrigation.

3.2.2 River basins and their catchment areas

i) Catchment areas.

Catchment areas of the river basins are come under cauvery basins in the district. The place of origins, total length and length within the district and area of the basin in sq.km are given in table no.25.

ii) Basin – wise status of the groundwater availability

Groundwater recharge and balance ground water available for development in the composite district of Trichy are 222805 ha.m and 90923 ha.m respectively. Basin-wise status of the ground water availability is given in the table no.26. Available water spread area in Karur districts are given in table no. 27.

iii) Details of dams and reservoirs

There are no dam and reservoirs in the district Refer table No.28

iv) *Irrigation by different sources*

The total cropped area is 1,39,651 hectares and the percentage of irrigated area to cropped area is 29.71. The block wise details of gross area irrigated were not available in the district. The details on irrigated area by different sources are given in table no: 29.

v) *Incidence of drought, flood and cyclone*

There are 4 Taluks and 8 Blocks in the district. It has been ascertained from the available information that 4 Taluks and 8 Blocks were affected by drought during the years 1993-94 & 1995-96 and affected by flood during 1988-89 to 1992-93 and 1995-96 and cyclone during the years 1994-95. The details on drought, flood and cyclone are given in Table No: 30.

3.2.3 Fisheries production

There is no estuaries & brackish water area in the district. The fish production fluctuates both in quantity and value from 1991 to 1996. The details are given in Table No: 31. Inland fish production is done in the district.

i. *General fish seed production*

The inland fish production fluctuates between 1986 to 1996 in the district. The district does not have fish seed production in the district. The details on fish and fish seed production are given in Table No: 32.

3.2.4 Heritage resources

i. Protected and conserved monuments

Pukalzimalai in Velayuthapalayam village is protected and conserved monument by Archaeological Survey of India (Refer Table No: 33).

ii. Places of tourist attraction

Karur, an important town of the district is located on the bank of the river amaravati. This town is one of the seven sacred sthalams or sivalayams and is well known for the famous pasupathiswami temple. The group of sculptures representing pasupathiswara, lingam as high as five feet bathed by the milk oozing from the udder of a cow and ranganatha are noted for cultural beauty. Pugalur situated north-west of Karur has gathered importance in recent years due to the setting-up of an integrated newsprint cum-paper project of the Tamilnadu Government. The temple here dedicated to lord subramania on a small hill near cauvery is noted for excellent sculpture. This village is famous for cultivation of plantains, which is exported in large number to other places.

Pasupathinathaswami temple and Subramaniyar temple are the two main tourist spots in the district, which are visited throughout the year. Tourist arrival both domestic and foreign has increased. (Refer Table No: 34 & 35).

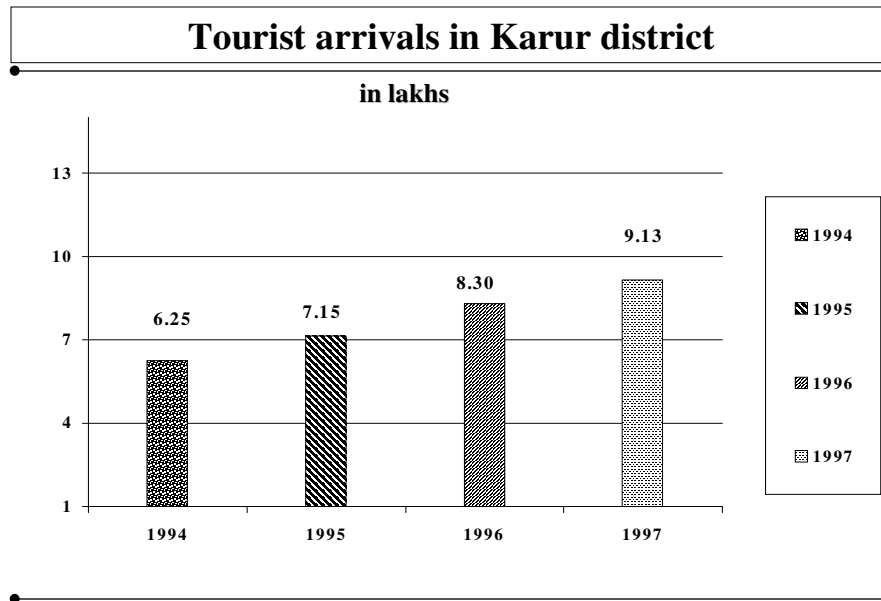

3.2.5 Energy resources

i. Installed power projects

There have been no installed power projects in the district (Refer Table No: 36).

ii. Consumption of electricity

Details of consumption of electricity are not available in the district. Refer Table No: 37.

iii. Electrification of villages

Karur district has achieved 100% electrification prior to 1995-96. All 172 villages in the district are electrified. The status on electrification of the energised pumpsets is

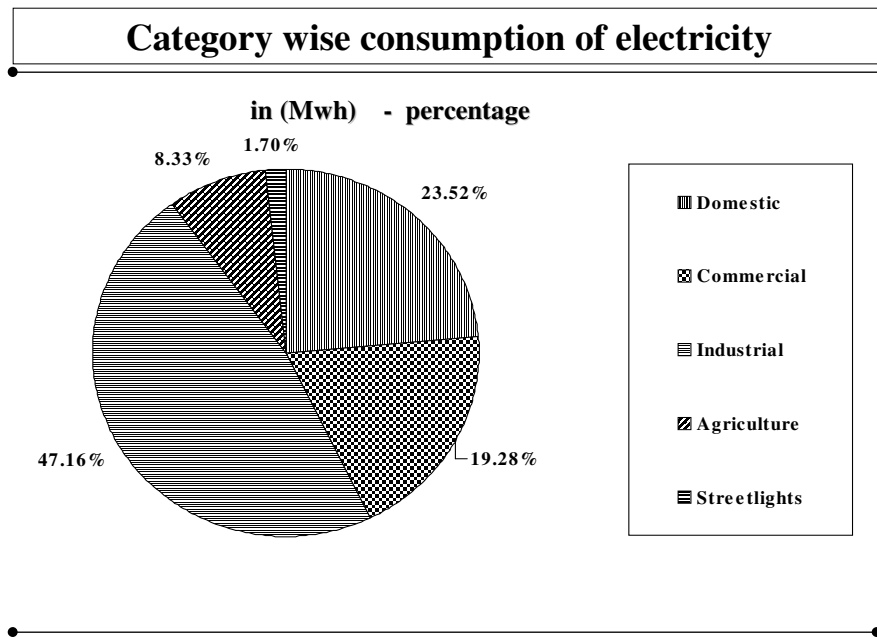

furnished in Table No: 38.

iv. Non conventional & renewable energy sources utilisation

Information is not available on non-conventional & renewable energy sources utilisation. Refer table no.39.

4.1 Urbanisation

4.1.1 Urbanisation pattern

The proportion of urban population to total population has increased during 1981-91 from 6.78% to 22.85% and is estimated at about 21.19% during 1996. Among the urban areas, Inamkarur town panchayat account for a greater share of urban population while compared to the other urban areas. The proportion of rural population to total population has decreased from 81.01% to 66.57% during the years 1981-1996. The urbanisation pattern of the district is given in Table No: 40.

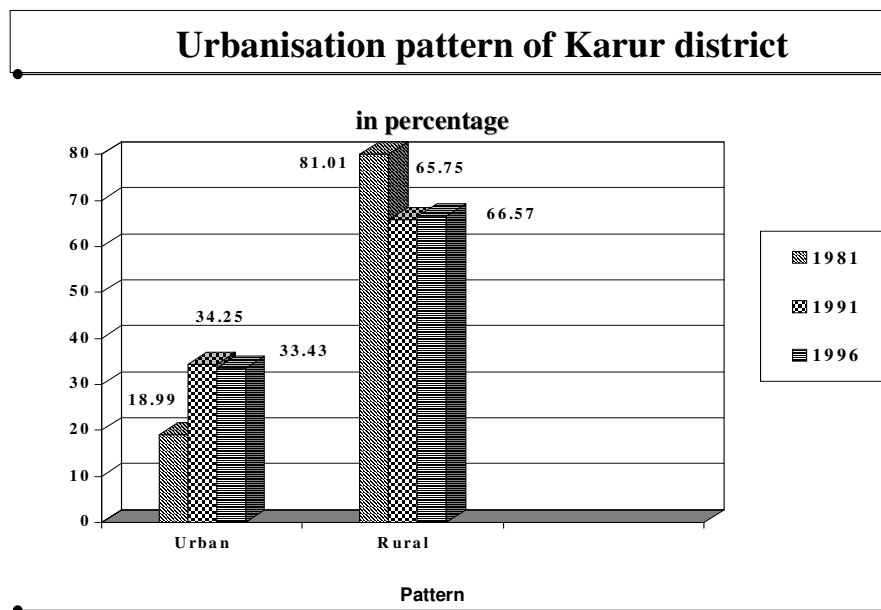

4.1.2 Density of population

The overall density of population has increased from 265 persons / sq.km in 1981 to 372 persons / sq.km in 1996. The density in urban area has fluctuates from 3058 persons/sq.km in 1981 to 9289 persons/sq.km in 1996 and the density of rural area has decreased from 218 persons/sq.km in 1981 to 251 persons/sq.km in 1996. The details on density are given in Table No: 41.

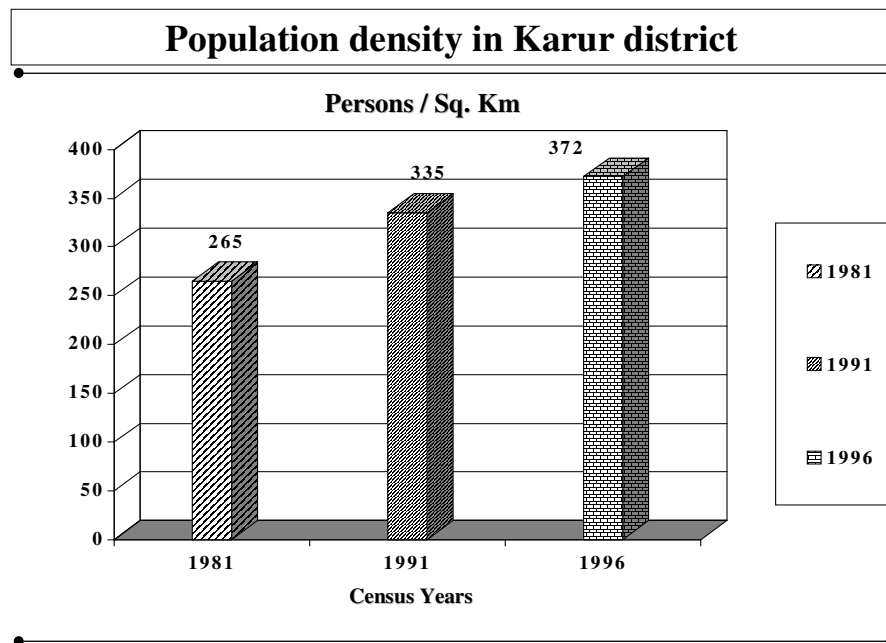

4.1.3 Decadal growth rate in urban centres

The decadal growth rates in town panchayat have increased in 1991. The population of the district has grown from 6.21 lakhs in 1961 to 8.54 lakhs in 1991. Inamkarur has the maximum growth rate among the town panchayat. The details of decadal growth rate are given in Table No:

42. The decennial growth rate for both urban and rural population over the past three decades has increased steadily from 1961 to 1996 (Refer Table No: 43).

4.1.4 Urban population

There has been an increase in the percentage of urban population to total population from 1991 to 1996. Inamkarur has the maximum number of urban Population (43451 persons) and Jayamkondacholapuram has the minimum number of urban population (7072 persons) in 1996 among the town panchayat. The district does not have slums. Necessary details are given in Table No: 44.

4.1.5 Trend in urbanisation and slums

There has been a steady increase in the percentage of urban population to total population from 18.99 in 1981 to 33.43 in 1996 in the district. Refer Table No: 45.

4.2 Infrastructure services and environmental status

4.2.1 Occupied housing units

Total urban areas occupied households in Karur district is 954040 out of the total households in urban areas 781335 households does not have any type of toilet facility. The details are given in Table No.46.

4.2.2 Urban services

Ground water is the major sources for protected water supply system for town panchayat with an average water supply of 52.36 LPCD. The town panchayat of Inamkarur

have 24.3 lakhs litres and aravankurichi have 3.1 lakhs litres respectively. Details on water supply services are given in Table No: 47a & 47b.

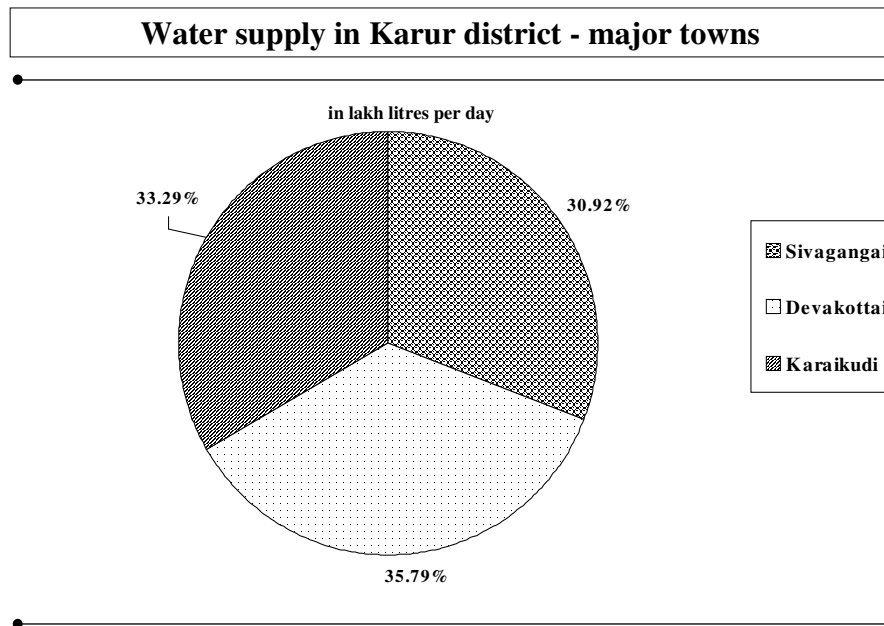

4.2.3 Domestic waste water generation and treatment

The estimated sewage generation is 78.33 lakhs litres among town panchayat. The district does not have any organised disposal of sewage. Nature of disposal and quantity through water body reservoir is 25.69 lakhs litres in town panchayat. The district has complete open drainage system. The details on domestic wastewater generation and

treatment in the district are given in Table No: 48.

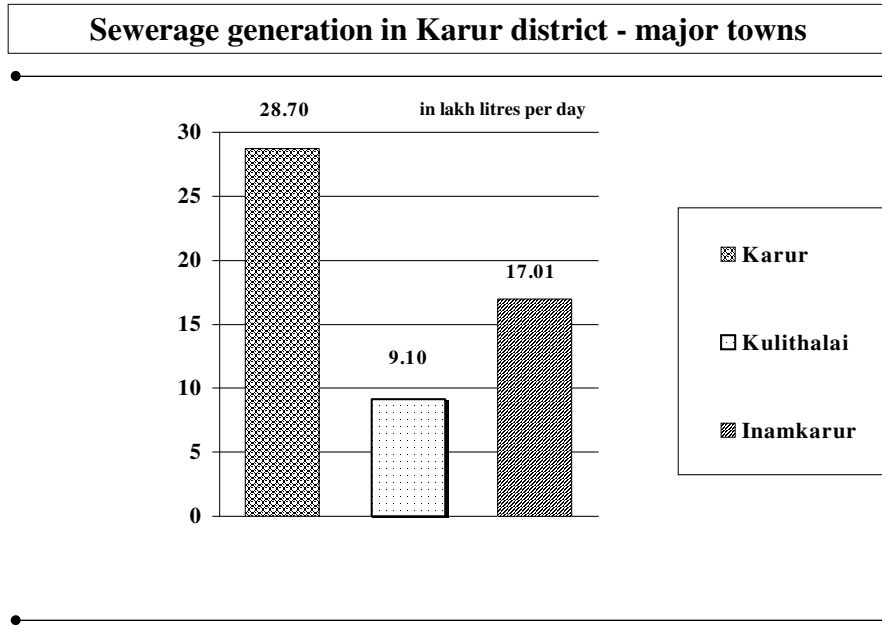

4.2.4 Municipal solid waste generation

The solid waste generation of town panchayat is 57.56 metric tonnes. The solid waste collection of town panchayat is 47.25 metric tonnes as on 1995-96. Overall the solid waste generated adds up to 57.56 metric tonnes with a collection efficiency of 87.31% and with a manpower of 108 for Solid waste management. (Refer Table No: 49).

Solid waste generation and collection in Karur district - major towns

in tonnes per day

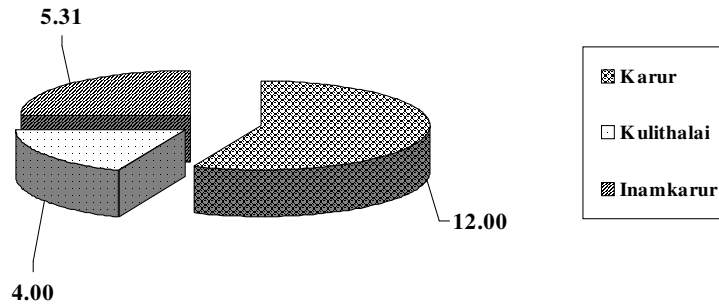

4.2.5 Composition of solid waste

Compostable matter covers 87% and other compositions like glasses, rubber & leather and plastics etc. cover 13% in Karur district (Refer Table No: 50).

4.2.6 Coverage of problem villages

Total of 867 problem villages was identified as on 1986. Out of which 749 problem villages were covered during VIII five-year plan period (Refer Table No: 51).

4.2.7 Reported cases of water borne diseases

Maximum of 250 persons affected by Gastro-enteritis in 1992-93 and 273 persons affected by Dysentery in 1985. Details about reported cases of water borne diseases are given in Table No.52.

4.2.8 Facilities under Indian system of medicines

The following table provides information on types of medical facilities available in the towns of this district including those of beds facilities available therein:

| No | Name of the towns | Medical institutions | (with beds) |
|----|-------------------|----------------------------|-------------|
| 1 | Karur U.A | | - |
| | I) Inam Karur | - | |
| | II) Karur | Hospital (1) | 111 |
| | | Dispensary (1) | - |
| | | Family Planning Centre (1) | - |
| | | Others (1) | 9 |
| 2 | Kulithalai | Hospital (1) | 24 |
| 3 | Manapparai | Hospital (1) | 22 |
| | | Dispensary (1) | - |
| 4 | Pallappatti | Hospital (1) | 21 |
| 5 | Punjai Pugalur | Hospital (1) | 8 |
| | | Others (1) | - |

Allopathic is the most commonly practised system of medicine facilities in the district. There are in addition, a few siddha hospitals & dispensaries are also available. The details on the facilities available under Indian systems of medicines in the district are given in Table No.53.

4.2.9 Population below poverty line

As per the population below poverty line survey done in 1996 number of family below poverty line is 62093 in the district.

4.3 Transportation

National highways No.7 and state highways pass through this district. It is also well connected by railways. A broad gauge line of Southern railways which runs between Erode junction and Thiruchirappali interlinked Karur, the district headquarters and Kulithalai, an important town of this district as well

4.3.1 Development of roads, bridges

The district has 118.2 km. of National highway, 58.41 km of State highways, 260.6 km. of Major district roads, 610.45 of other district roads and 2236.06 km of Panchayat roads maintained by urban local bodies in the years 1991-96. Over and above, there are 1712 minor bridges and culverts and four major bridges in the district in the year 1996. Relevant information is provided in Table No: 56.

4.3.2 Growth of vehicle population

There has been a significant increase of two, three and four wheeler vehicles in the district over the past 10 years. The total number of two, three and four wheelers in 1997 is 6541, 37 and 566 respectively. The details on the growth of vehicle population are given in Table No: 55.

4.4 Industrial development and environmental status

The Tamilnadu Newsprint and Papers Limited is setting-up an integrated newsprint-cum-paper project at Pugalur in the district for the manufacture of 50000 tonnes of printing paper per annum. This project estimated to cost around Rs.190 crore (including working capital) is a joint venture of the Government of Tamilnadu, Indian financial institutions and the World bank. The Handloom industry has been a traditional occupation of this district. This industry flourishes mainly in Karur. An export production centre has been set- up at Karur with an installed capacity of 942 looms. This project which was set-up by the Tamilnadu Government at a cost of Rs.40.75 lakhs produced 5.71 lakh metres of handloom fabrics valued at Rs.53.80 lakh.

Major items of production by the weavers of the co-operative societies consist of cotton sarees and dhoties of 80100 and 120 counts. Bed sheets woven in Karur area popularly known as 'Karun bed sheets' are known for their designs and variety.

4.4.1 Number of industries

There has been 34 Red category and 8 Orange category industries in large scale in 1995-96, which are classified based on the nature of hazardous by TNPCB. Red category industries are mostly textiles, chemicals and pharmaceutical industries. The details on the number of industries are given in table no.57.

4.4.2 Emission inventory of major industries

E.I.D. Parry (India) limited has been identified with the highest emission rate in terms of SPM ($227.86 \mu\text{g}/\text{m}^3$), SO ($4.67 \mu\text{g}/\text{m}^3$), NO ($3.1 \mu\text{g}/\text{m}^3$) while the emission rates of CO and HC are not available from the authorities. Chettinad cement has also identified with the highest emission rate of SO₂ ($5.99 \mu\text{g}/\text{m}^3$) and NO_x ($5.22 \mu\text{g}/\text{m}^3$). The details of emission inventory of major industries are given in Table No: 58.

4.4.3 Ambient air quality status

As far as the urban air quality status is concerned, the average SPM values and average NO_x values of commercial and industrial categories seem to be within the standards. However, the maximum value of these indicators is far beyond the set standards causing concern (Refer Table No: 60).

4.4.4 Air pollution stressed area

Puliyur and Kagithapuram are the air pollution stressed areas with the major air pollutant being paper mill and cement plants. (Refer Table No: 59).

4.4.5 Water quality

Well water has become unfit for any kind of use viz, drinking, irrigation, cattle feeding etc., due to the presence of excessive amounts of pollutants present in the samples. The presence of higher amounts of total dissolved solids makes the toxic substances under-gradable. So, the toxic

substances persist for long time, thereby it severely affects the water quality. If their polluted waters are used for irrigation purpose it will affect the osmotic-pressure regulating mechanism of the plants.

Under MINAR's scheme TNPCB is monitoring the quality of water from Trichy U/S and Kallanai. PH & DO centre of water is exceeded the standard value. More coliform content is also found out in this water. Water quality of composite Thiruchirappalli district is furnished in the table no. 61.

4.4.6 Discharge of industrial effluents

The dyeing units discharging the effluents in the irrigation canals are the major problem. The water resources seem to be frequently affected, bore well water and irrigation canals coming from amaravathi dam.

Textile related factories like dyeing & bleaching were discharged effluents into the Amaravathi River. Mallika dyeing, kasthuri dyeing, Tamilnadu Newsprint & Papers and EID Parry (India) ltd. were discharged effluents in the Kudamurutti river. Quantity of effluents discharged into river factory-wise is given in the Table No: 62.

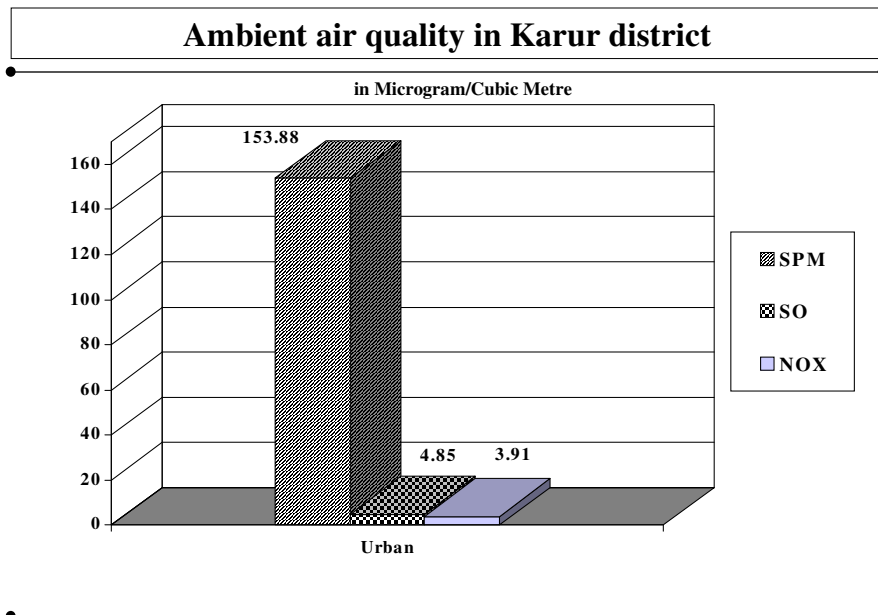

4.4.7 Noise levels

Noise level in commercial and residential area were exceed the ambient noise standard in Karur district. Details of Noise level are given in the Table No: 63.

4.4.8 Wet land Habitats, their use and Problems.

48002 ha.of Water Spread Area are available in the district. Moat of the lakes are used for irrigation purpose pollution identified in these lakes are low. (Refer Table No. 64)

I. Trade, commerce and export

The table given below provides information on most important commodities manufactured, exported from and imported in the towns of this district. It also indicates the number of banks available in the towns of this district.

| No | Name of the towns | Most important commodities | | | Banks |
|----|-------------------|----------------------------|----------|--------------|-------|
| | | Manufactured | Exported | Imported | |
| 1 | Karur U.A | Handloom | Handloom | - | - |
| | I) Inam Karur | Cloth | | | |
| | II) Karur | Handloom bed sheet | Turmeric | Oil seeds | 17 |
| 2 | Kulithalai | - | - | Paddy | 6 |
| 3 | Manapparai | - | Chillies | Rice | 5 |
| 4 | Pallappatti | - | - | - | 1 |
| 5 | Punjai Pugalur | Sugar | Sugar | - | 2 |

Environmental institutions

5.1 Environmental education and research institutions

There have been no educational and research institutions in the district. Refer Table No.65.

5.2 Environmental NGOs

There have been 2 NGOs dealing with environmental related issues in the district. Their main activities are environmental awareness, to form students environmental committee, employment training and welfare for women. The details of the NGO's activities related environment is given in Table No: 66.

Summary of observations

The key observations of the environmental profile of Karur district are briefed below:

Demographic details

The growth rate of population has been on an increase at about 1.28% per annum during the period of 1981-91.

It is encouraging to note that the female literacy rate has significantly increased in the past 15 years.

Agriculture

Utilisation of land area in Karur district is upto 44.59%. 4.76% of the land area remains as other uncultivated land.

The total use of chemical fertilisers and the total use of Bio-fertilisers were 20422 tonnes and 13000 pockets respectively.

Black soil is the predominant Soil type in this district accounting for 35.51% followed by lateritic Soil for 23.85%. The other type of soil is sandy, coastal alluvium for 20.31%.

The use of irrigation purposes for 20477 wells. 2.74 % if forest area in Karur district.

River basins and their catchment areas

The main sources of irrigation of the district happen to be canals, tanks, wells and other sources are nearly 29.71% of the total cropped areas are irrigated by these sources.

Heritage resources

There are two tourist places in the district. Both domestic and foreign tourist arrivals have increased.

Urbanisation

Urbanisation process in Karur district is taking place at a higher rate. There is an increase in urban population in Karur district for the past fifteen-year's.

There is no improvement of urban services particularly protected drinking water and solid waste management in the district.

There is a significant growth of two, three and four wheeler vehicles in the district over the ten years.

The Red, Orange and Green categories of hazardous Industries are identified by TNPCB. Most of the Red category industries are very hazardous in nature.

There is no environmental education institutes in the Karur district. Two NGOs dealing with Environmental related issues in the district.

Participative planning for environment management,

creation of a management information system, environment management training to officers of the stake-holding government departments would go a long way in the environment planning efforts of the **Directorate of Environment, Government of Tamilnadu** in fulfilling its corporate objectives.

